

HHOSUG

9. Meeting

IP Multipathing

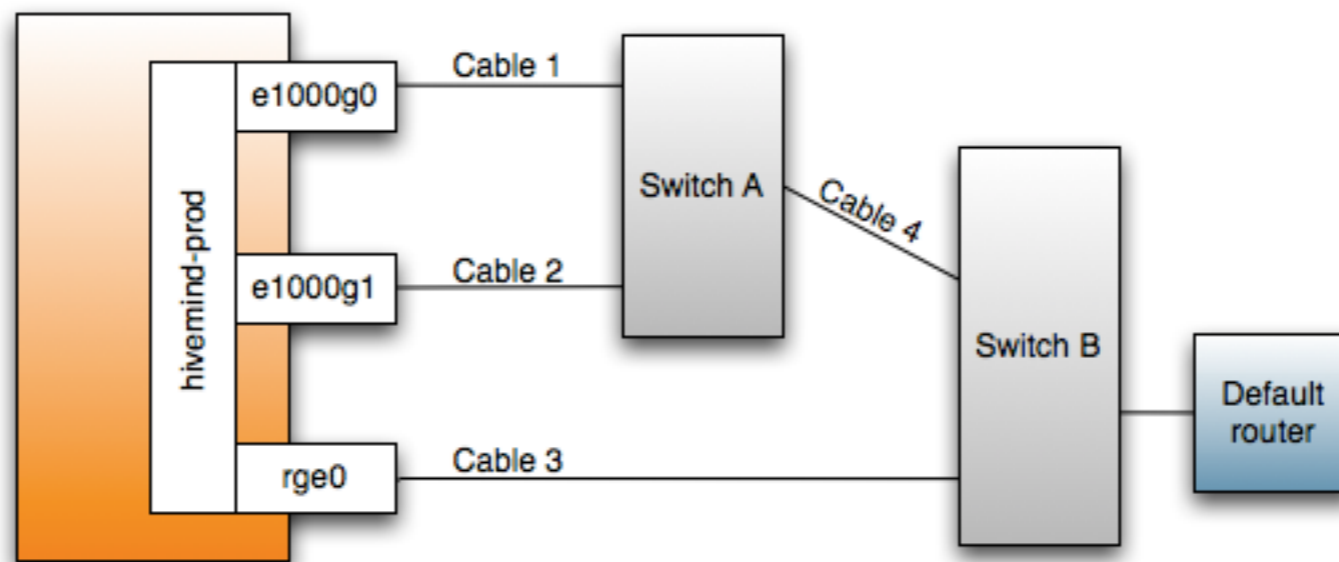

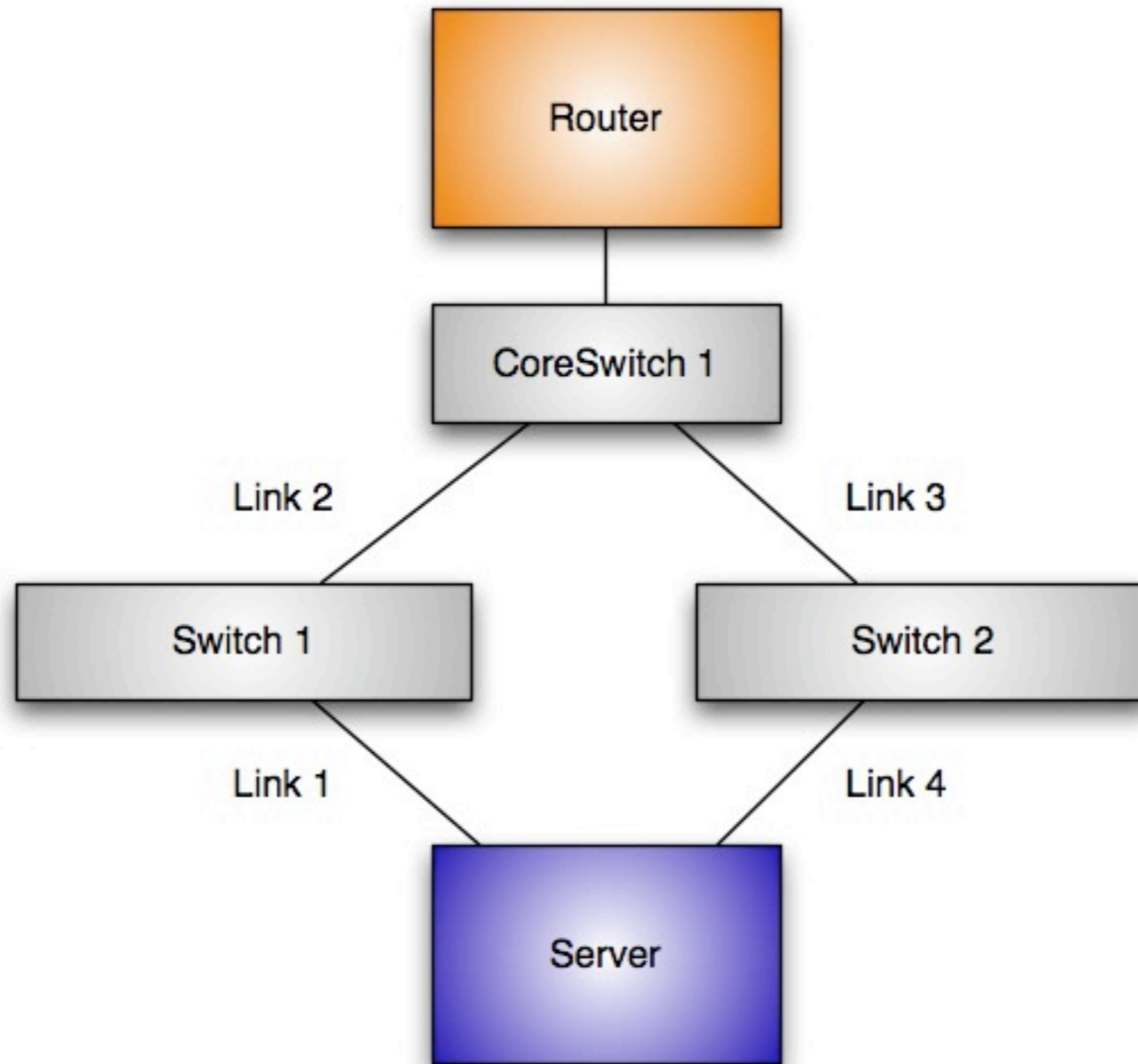

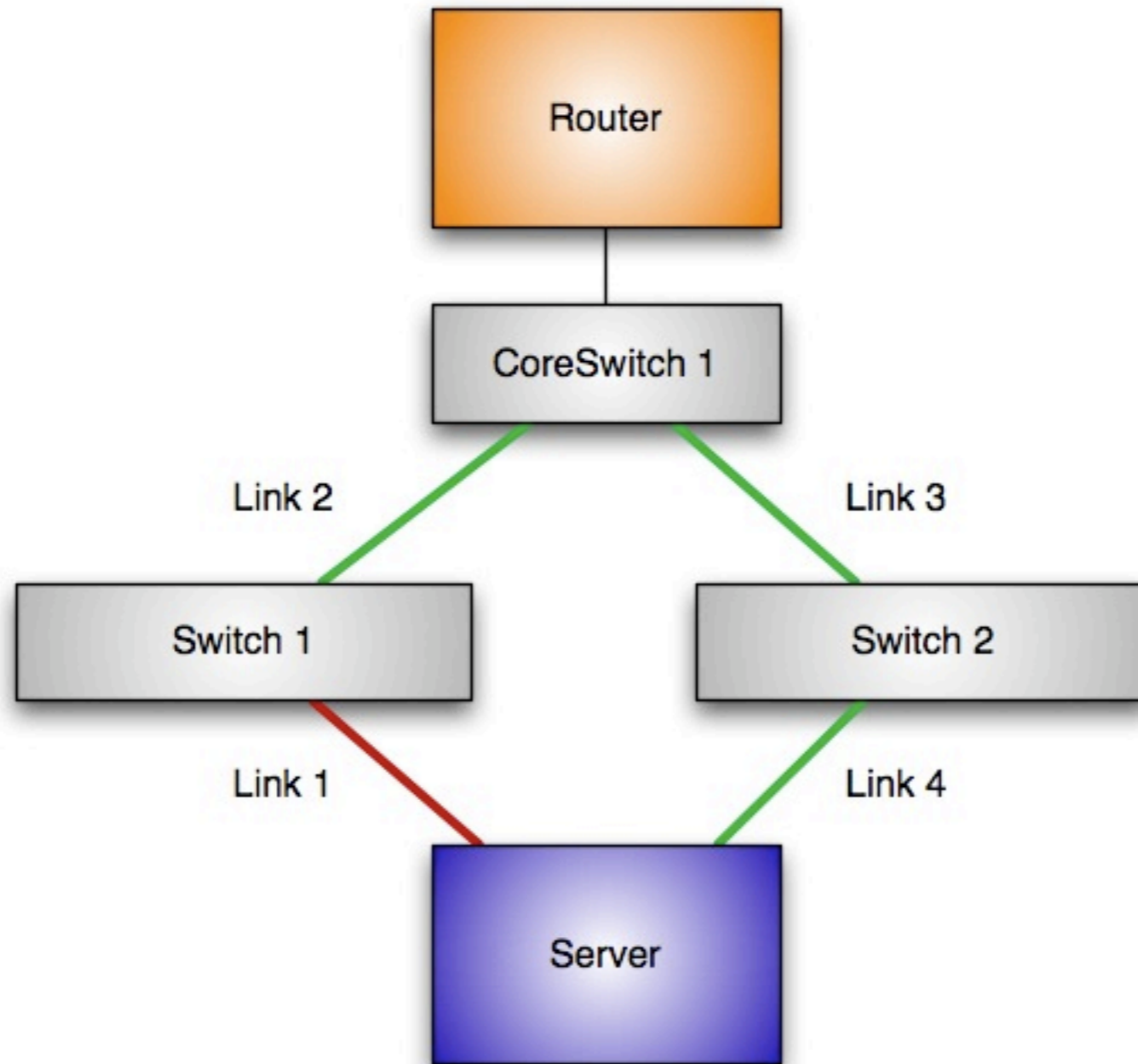

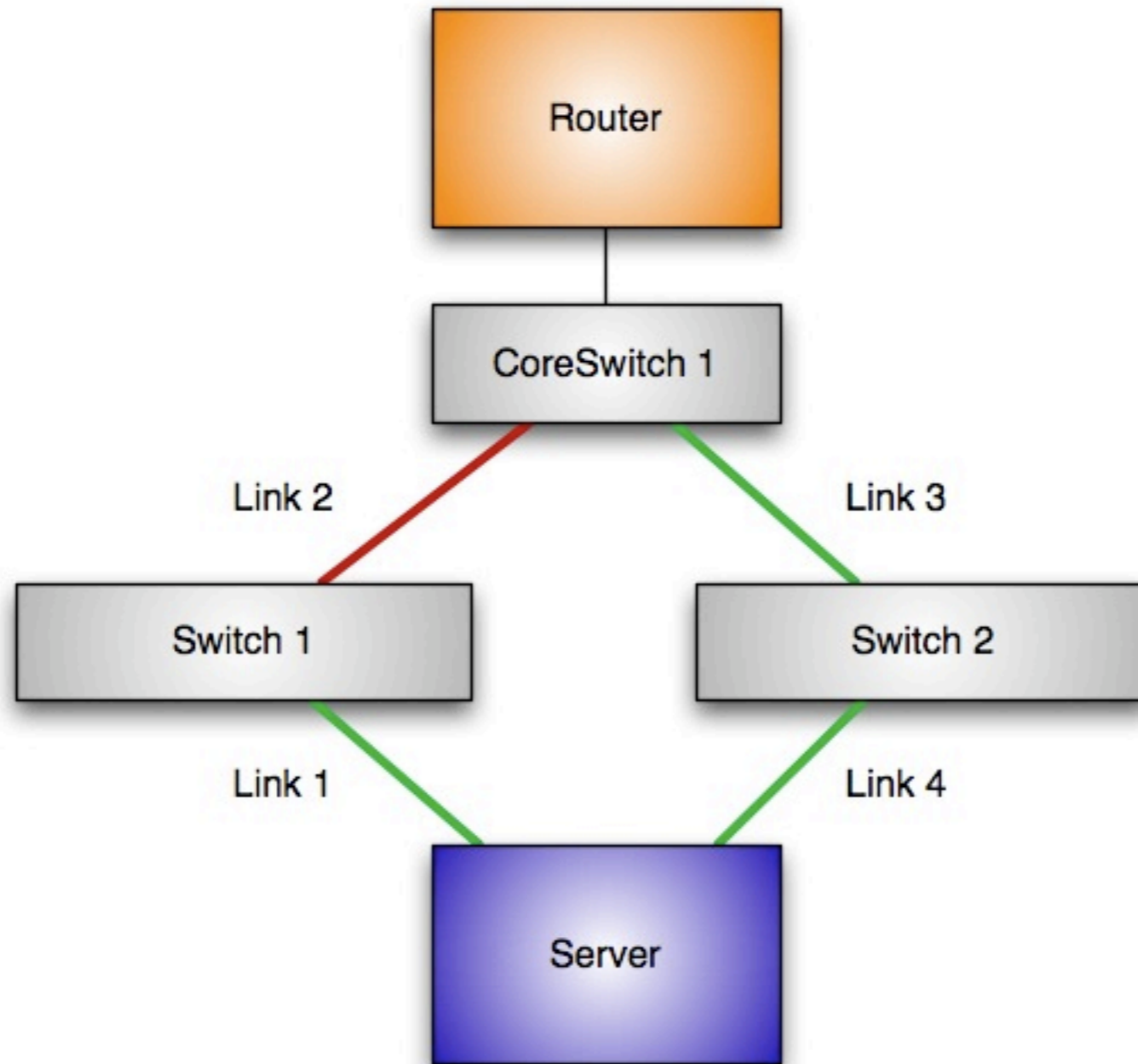

IPMP group: production0

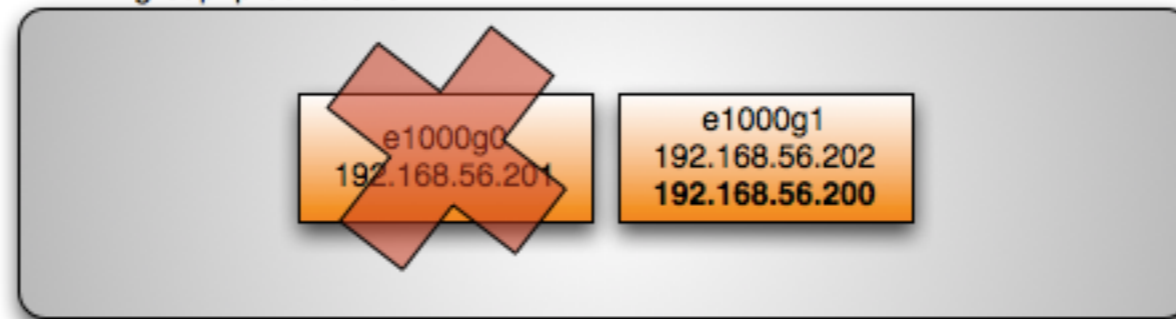

IPMP group: production0

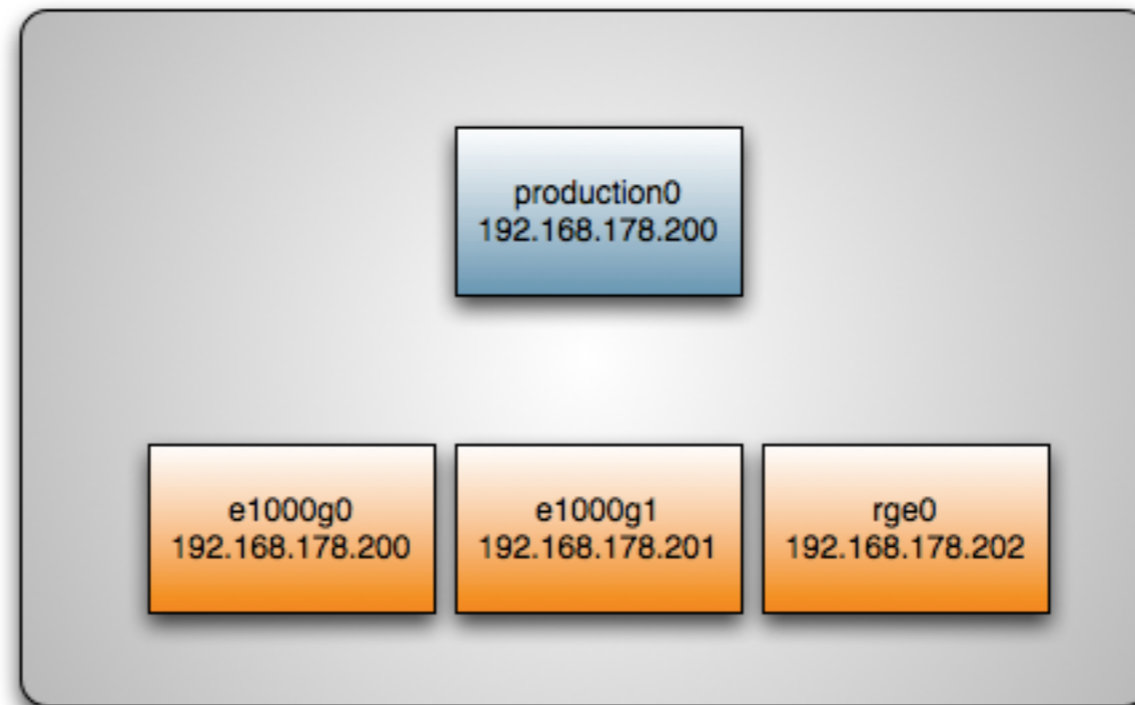

IPMP group: production0

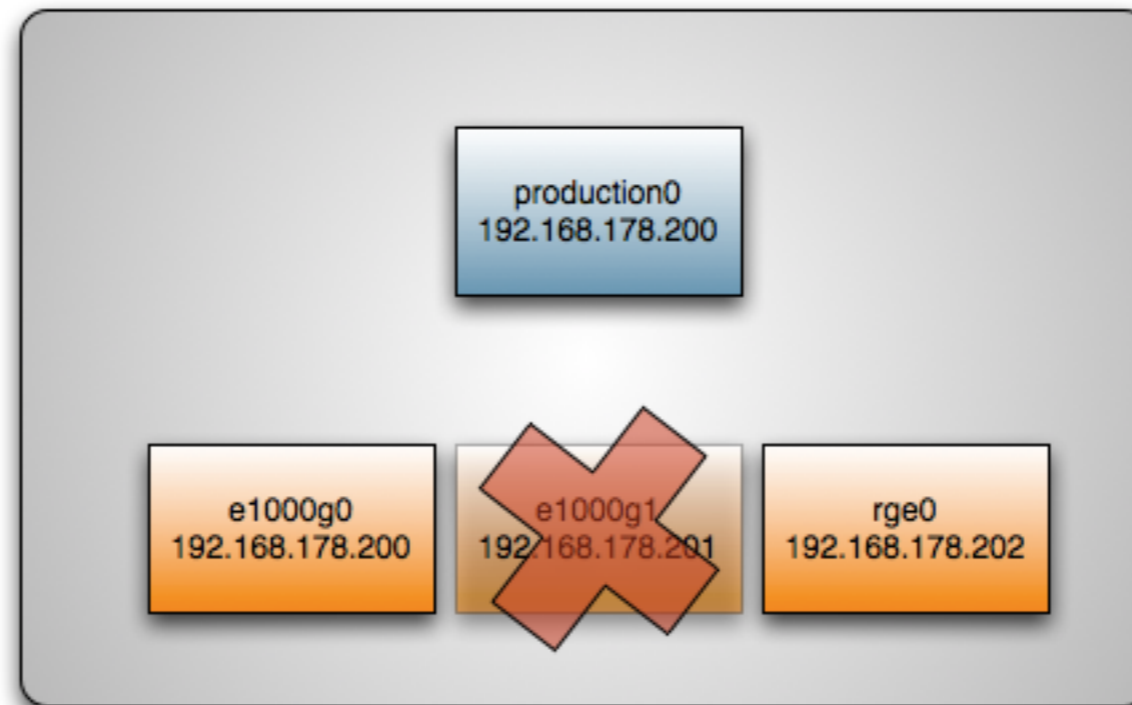

Link Aggregation

viele kennen das unter
EtherChannel

EtherChannel hat den
Nachteil und den Vorteil
das die Config statisch ist.

Fehlkonfigurationen fallen kaum auf ...

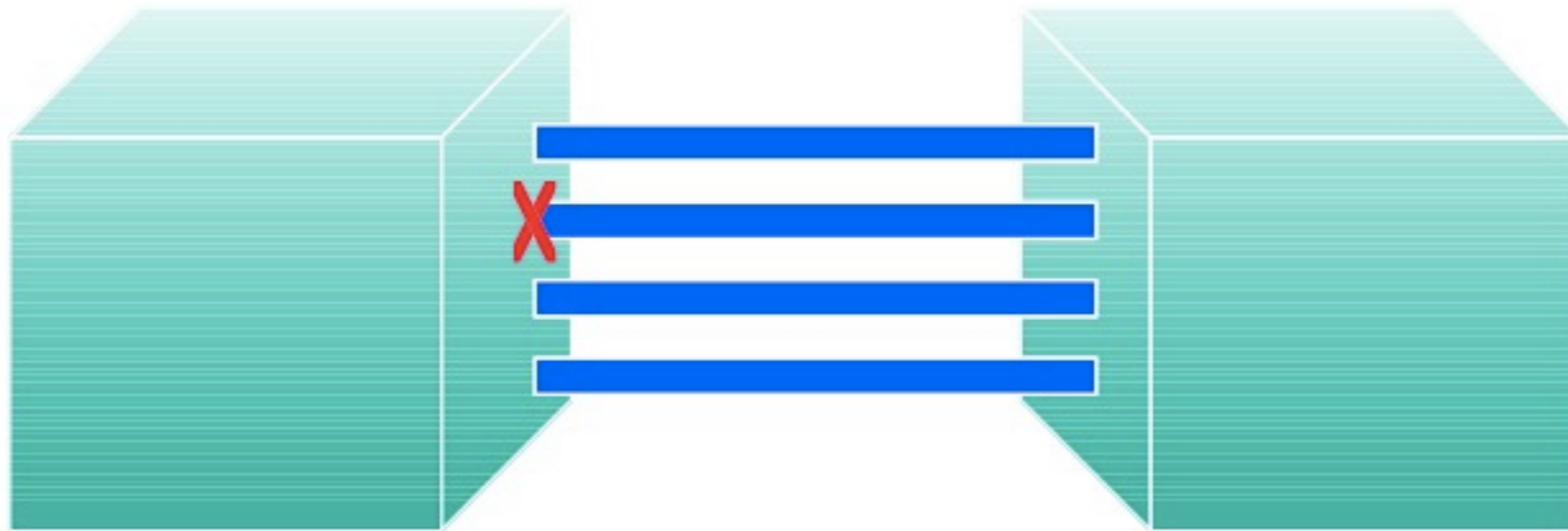

Fehlkonfigurationen fallen kaum auf ...

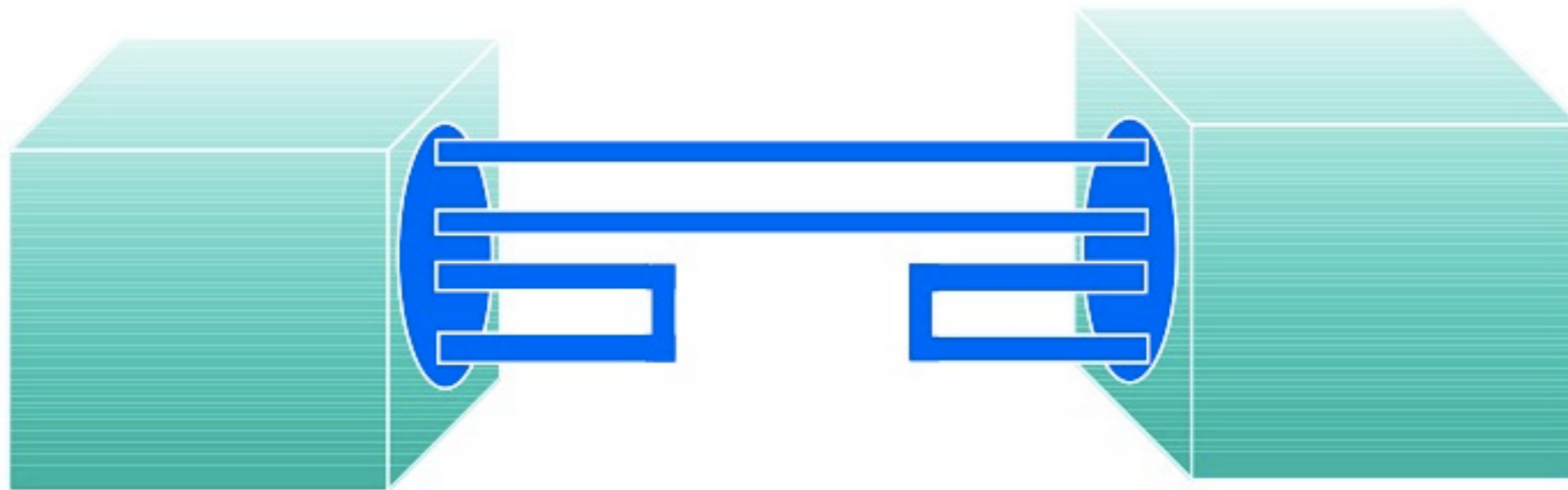

Fehlkonfigurationen fallen kaum auf ...

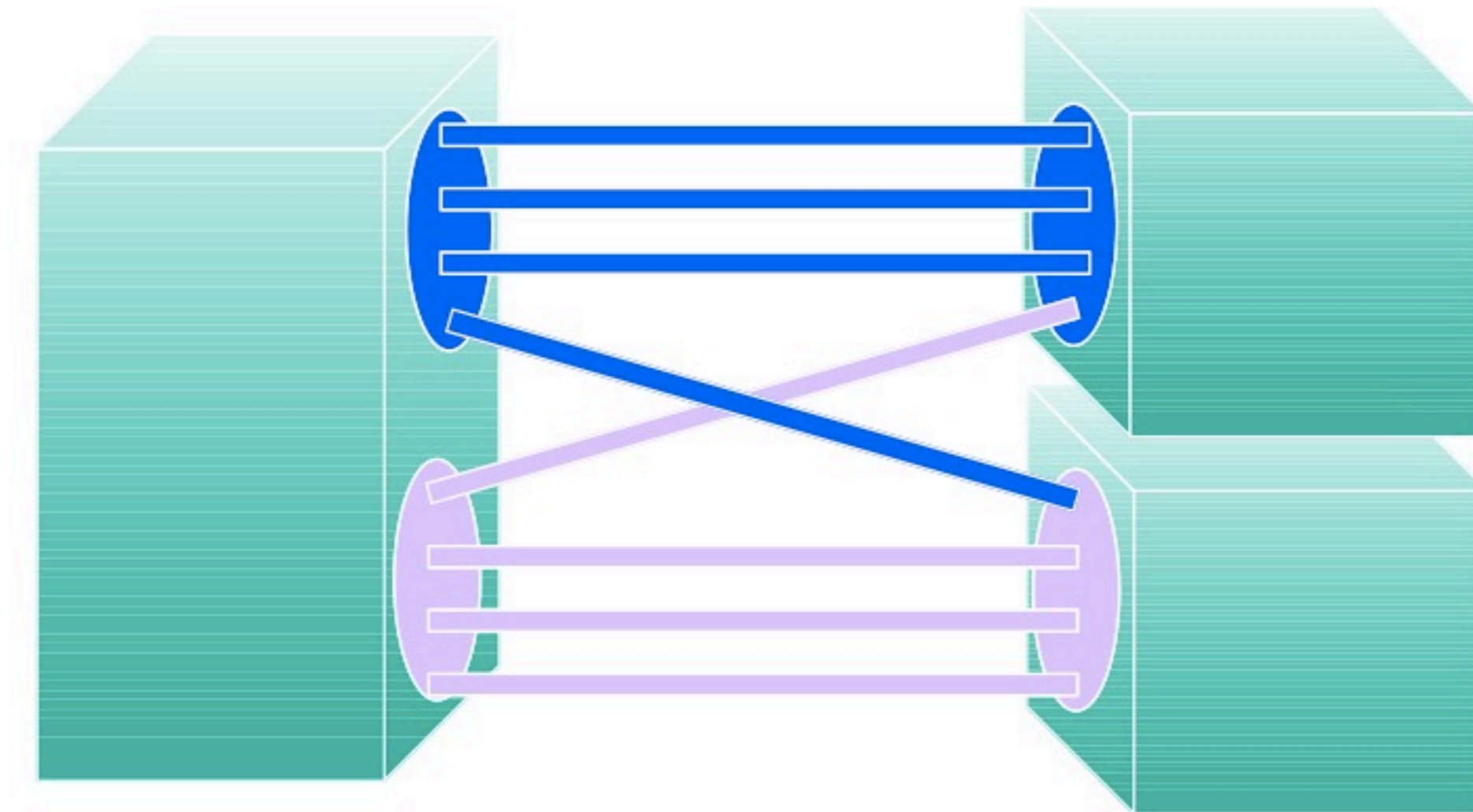

Cisco erfand dann das PAgP
(Port Aggregation Protocol)

Konnte selbständig herausfinden
das zu einem anderen Switch
mehrere
Verbindungen führten und aggregierte
diese ...

Dummerweise:
Cisco only ...

Offener Standard:
Link Aggregation Control Protocol
IEEE 802.3ad

LACP
ist interessant:

Es ist ein echtes Tratschprotokoll

Die Beteiligten
sprechen nicht wirklich miteinander
sondern nur übereinander

Destination ist immer
01:80:c2:00:00:02



01-80-C2-00-00-01	IEEE 802	"	IEEE MAC-specific control protocols
01-80-C2-00-00-02	IEEE 802	"	IEEE Std 802.3 Slow Protocols multicast address
01-80-C2-00-00-03	IEEE 802	"	IEEE Std 802.1X PAE address

Slow Protocols?

01-80-C2-00-00-01	IEEE 802	"	IEEE MAC-specific control protocols
01-80-C2-00-00-02	IEEE 802	"	IEEE Std 802.3 Slow Protocols multicast address
01-80-C2-00-00-03	IEEE 802	"	IEEE Std 802.1X PAE address

Slow Protocol heisst
nicht mehr als 5 Frames in einer Sekunde.

```
Frame 1 (124 bytes on wire, 124 bytes captured)
Ethernet II, Src: Procurve_8f:3a:32 (00:25:61:8f:3a:32), Dst: Slow-Protocols (01:80:c2:00:00:02)
Link Aggregation Control Protocol
  Slow Protocols subtype: LACP (0x01)
  LACP Version Number: 0x01
  Actor Information: 0x01
  Actor Information Length: 0x14
  Actor System Priority: 32768
  Actor System: Procurve_8f:3a:30 (00:25:61:8f:3a:30)
  Actor Key: 26
  Actor Port Priority: 128
  Actor Port: 3
  Actor State: 0xc5 (Activity, Aggregation, Defaulted, Expired)
    .... .1 = LACP Activity: Yes
    .... ..0. = LACP Timeout: No
    .... .1.. = Aggregation: Yes
    .... 0... = Synchronization: No
    ...0 .... = Collecting: No
    ..0. .... = Distributing: No
    .1.. .... = Defaulted: Yes
    1... .... = Expired: Yes
  Reserved: 000000
  Partner Information: 0x02
  Partner Information Length: 0x14
  Partner System Priority: 0
  Partner System: 00:00:00_00:00:00 (00:00:00:00:00:00)
  Partner Key: 0
  Partner Port Priority: 0
  Partner Port: 0
  Partner State: 0x07 (Activity, Timeout, Aggregation)
    .... .1 = LACP Activity: Yes
    .... ..1. = LACP Timeout: Yes
    .... .1.. = Aggregation: Yes
    .... 0... = Synchronization: No
    ...0 .... = Collecting: No
    ..0. .... = Distributing: No
    .0.. .... = Defaulted: No
    0... .... = Expired: No
```

Switch 2 Server

```
Frame 2 (124 bytes on wire, 124 bytes captured)
Ethernet II, Src: Procurve_8f:3a:32 (00:25:61:8f:3a:32), Dst: Slow-Protocols (01:80:c2:00:00:02)
Link Aggregation Control Protocol
  Slow Protocols subtype: LACP (0x01)
  LACP Version Number: 0x01
  Actor Information: 0x01
  Actor Information Length: 0x14
  Actor System Priority: 32768
  Actor System: Procurve_8f:3a:30 (00:25:61:8f:3a:30)
  Actor Key: 26
  Actor Port Priority: 128
  Actor Port: 3
  Actor State: 0xc5 (Activity, Aggregation, Defaulted, Expired)
    .... ...1 = LACP Activity: Yes
    .... ..0. = LACP Timeout: No
    .... .1.. = Aggregation: Yes
    .... 0... = Synchronization: No
    ...0 .... = Collecting: No
    ..0. .... = Distributing: No
    .1.. .... = Defaulted: Yes
    1... .... = Expired: Yes
  Reserved: 000000
  Partner Information: 0x02
  Partner Information Length: 0x14
  Partner System Priority: 0
  Partner System: 00:00:00_00:00:00 (00:00:00:00:00:00)
  Partner Key: 0
  Partner Port Priority: 0
  Partner Port: 0
  Partner State: 0x07 (Activity, Timeout, Aggregation)
    .... ...1 = LACP Activity: Yes
    .... ..1. = LACP Timeout: Yes
    .... .1.. = Aggregation: Yes
    .... 0... = Synchronization: No
    ...0 .... = Collecting: No
    ..0. .... = Distributing: No
    .0.. .... = Defaulted: No
    0... .... = Expired: No
```

Switch 2 Server

```
Frame 3 (124 bytes on wire, 124 bytes captured)
Ethernet II, Src: Procurve_8f:3a:32 (00:25:61:8f:3a:32), Dst: Slow-Protocols (01:80:c2:00:00:02)
Link Aggregation Control Protocol
  Slow Protocols subtype: LACP (0x01)
  LACP Version Number: 0x01
  Actor Information: 0x01
  Actor Information Length: 0x14
  Actor System Priority: 32768
  Actor System: Procurve_8f:3a:30 (00:25:61:8f:3a:30)
  Actor Key: 26
  Actor Port Priority: 128
  Actor Port: 3
  Actor State: 0xc5 (Activity, Aggregation, Defaulted, Expired)
    .... .1 = LACP Activity: Yes
    .... ..0. = LACP Timeout: No
    .... .1.. = Aggregation: Yes
    .... 0... = Synchronization: No
    ...0 .... = Collecting: No
    ..0. .... = Distributing: No
    .1.. .... = Defaulted: Yes
    1... .... = Expired: Yes
  Reserved: 000000
  Partner Information: 0x02
  Partner Information Length: 0x14
  Partner System Priority: 0
  Partner System: 00:00:00_00:00:00 (00:00:00:00:00:00)
  Partner Key: 0
  Partner Port Priority: 0
  Partner Port: 0
  Partner State: 0x07 (Activity, Timeout, Aggregation)
    .... .1 = LACP Activity: Yes
    .... ..1. = LACP Timeout: Yes
    .... .1.. = Aggregation: Yes
    .... 0... = Synchronization: No
    ...0 .... = Collecting: No
    ..0. .... = Distributing: No
    .0.. .... = Defaulted: No
    0... .... = Expired: No
```

Switch 2 Server

```
Frame 4 (124 bytes on wire, 124 bytes captured)
Ethernet II, Src: Procurve_8f:3a:32 (00:25:61:8f:3a:32), Dst: Slow-Protocols (01:80:c2:00:00:02)
Link Aggregation Control Protocol
  Slow Protocols subtype: LACP (0x01)
  LACP Version Number: 0x01
  Actor Information: 0x01
  Actor Information Length: 0x14
  Actor System Priority: 32768
  Actor System: Procurve_8f:3a:30 (00:25:61:8f:3a:30)
  Actor Key: 26
  Actor Port Priority: 128
  Actor Port: 3
  Actor State: 0x45 (Activity, Aggregation, Defaulted)
    .... ..1 = LACP Activity: Yes
    .... ..0. = LACP Timeout: No
    .... .1.. = Aggregation: Yes
    .... 0... = Synchronization: No
    ...0 .... = Collecting: No
    ..0. .... = Distributing: No
    .1.. .... = Defaulted: Yes
    0... .... = Expired: No
  Reserved: 000000
  Partner Information: 0x02
  Partner Information Length: 0x14
  Partner System Priority: 0
  Partner System: 00:00:00_00:00:00 (00:00:00:00:00:00)
  Partner Key: 0
  Partner Port Priority: 0
  Partner Port: 0
  Partner State: 0x0d (Activity, Aggregation, Synchronization)
    .... ..1 = LACP Activity: Yes
    .... ..0. = LACP Timeout: No
    .... .1.. = Aggregation: Yes
    .... 1... = Synchronization: Yes
    ...0 .... = Collecting: No
    ..0. .... = Distributing: No
    .0.. .... = Defaulted: No
    0... .... = Expired: No
```

Switch 2 Server

```
Frame 5 (124 bytes on wire, 124 bytes captured)
Ethernet II, Src: IntelCor_16:8d:7f (00:1b:21:16:8d:7f), Dst: Slow-Protocols (01:80:c2:00:00:02)
Link Aggregation Control Protocol
  Slow Protocols subtype: LACP (0x01)
  LACP Version Number: 0x01
  Actor Information: 0x01
  Actor Information Length: 0x14
  Actor System Priority: 4096
  Actor System: IntelCor_3d:91:f7 (00:1b:21:3d:91:f7)
  Actor Key: 1003
  Actor Port Priority: 4096
  Actor Port: 7
  Actor State: 0x0d (Activity, Aggregation, Synchronization)
    .... .1 = LACP Activity: Yes
    .... ..0. = LACP Timeout: No
    .... .1.. = Aggregation: Yes
    .... 1... = Synchronization: Yes
    ...0 .... = Collecting: No
    ..0. .... = Distributing: No
    .0.. .... = Defaulted: No
    0... .... = Expired: No
  Reserved: 000000
  Partner Information: 0x02
  Partner Information Length: 0x14
  Partner System Priority: 32768
  Partner System: Procurve_8f:3a:30 (00:25:61:8f:3a:30)
  Partner Key: 26
  Partner Port Priority: 128
  Partner Port: 3
  Partner State: 0x45 (Activity, Aggregation, Defaulted)
    .... .1 = LACP Activity: Yes
    .... ..0. = LACP Timeout: No
    .... .1.. = Aggregation: Yes
    .... 0... = Synchronization: No
    ...0 .... = Collecting: No
    ..0. .... = Distributing: No
    .1.. .... = Defaulted: Yes
    0... .... = Expired: No
```

Server 2 Switch

```
Frame 6 (124 bytes on wire, 124 bytes captured)
Ethernet II, Src: Procurve_8f:3a:32 (00:25:61:8f:3a:32), Dst: Slow-Protocols (01:80:c2:00:00:02)
Link Aggregation Control Protocol
  Slow Protocols subtype: LACP (0x01)
  LACP Version Number: 0x01
  Actor Information: 0x01
  Actor Information Length: 0x14
  Actor System Priority: 32768
  Actor System: Procurve_8f:3a:30 (00:25:61:8f:3a:30)
  Actor Key: 26
  Actor Port Priority: 128
  Actor Port: 3
  Actor State: 0x05 (Activity, Aggregation)
    .... ..1 = LACP Activity: Yes
    .... ..0. = LACP Timeout: No
    .... .1.. = Aggregation: Yes
    .... 0... = Synchronization: No
    ...0 .... = Collecting: No
    ..0. .... = Distributing: No
    .0.. .... = Defaulted: No
    0... .... = Expired: No
  Reserved: 000000
  Partner Information: 0x02
  Partner Information Length: 0x14
  Partner System Priority: 4096
  Partner System: IntelCor_3d:91:f7 (00:1b:21:3d:91:f7)
  Partner Key: 1003
  Partner Port Priority: 4096
  Partner Port: 7
  Partner State: 0x0d (Activity, Aggregation, Synchronization)
    .... ..1 = LACP Activity: Yes
    .... ..0. = LACP Timeout: No
    .... .1.. = Aggregation: Yes
    .... 1... = Synchronization: Yes
    ...0 .... = Collecting: No
    ..0. .... = Distributing: No
    .0.. .... = Defaulted: No
    0... .... = Expired: No
```

Switch 2 Server

```
Frame 7 (124 bytes on wire, 124 bytes captured)
Ethernet II, Src: Procurve_8f:3a:32 (00:25:61:8f:3a:32), Dst: Slow-Protocols (01:80:c2:00:00:02)
Link Aggregation Control Protocol
  Slow Protocols subtype: LACP (0x01)
  LACP Version Number: 0x01
  Actor Information: 0x01
  Actor Information Length: 0x14
  Actor System Priority: 32768
  Actor System: Procurve_8f:3a:30 (00:25:61:8f:3a:30)
  Actor Key: 26
  Actor Port Priority: 128
  Actor Port: 3
  Actor State: 0x0d (Activity, Aggregation, Synchronization)
    .... ...1 = LACP Activity: Yes
    .... ..0. = LACP Timeout: No
    .... .1.. = Aggregation: Yes
    .... 1... = Synchronization: Yes
    ...0 .... = Collecting: No
    ..0. .... = Distributing: No
    .0.. .... = Defaulted: No
    0... .... = Expired: No
  Reserved: 000000
  Partner Information: 0x02
  Partner Information Length: 0x14
  Partner System Priority: 4096
  Partner System: IntelCor_3d:91:f7 (00:1b:21:3d:91:f7)
  Partner Key: 1003
  Partner Port Priority: 4096
  Partner Port: 7
  Partner State: 0x0d (Activity, Aggregation, Synchronization)
    .... ...1 = LACP Activity: Yes
    .... ..0. = LACP Timeout: No
    .... .1.. = Aggregation: Yes
    .... 1... = Synchronization: Yes
    ...0 .... = Collecting: No
    ..0. .... = Distributing: No
    .0.. .... = Defaulted: No
    0... .... = Expired: No
```

Switch 2 Server

```
Frame 8 (124 bytes on wire, 124 bytes captured)
Ethernet II, Src: IntelCor_16:8d:7f (00:1b:21:16:8d:7f), Dst: Slow-Protocols (01:80:c2:00:00:02)
Link Aggregation Control Protocol
  Slow Protocols subtype: LACP (0x01)
  LACP Version Number: 0x01
  Actor Information: 0x01
  Actor Information Length: 0x14
  Actor System Priority: 4096
  Actor System: IntelCor_3d:91:f7 (00:1b:21:3d:91:f7)
  Actor Key: 1003
  Actor Port Priority: 4096
  Actor Port: 7
  Actor State: 0x3d (Activity, Aggregation, Synchronization, Collecting, Distributing)
    .... .1 = LACP Activity: Yes
    .... ..0. = LACP Timeout: No
    .... .1.. = Aggregation: Yes
    .... 1... = Synchronization: Yes
    ...1 .... = Collecting: Yes
    ..1. .... = Distributing: Yes
    .0.. .... = Defaulted: No
    0... .... = Expired: No
  Reserved: 000000
  Partner Information: 0x02
  Partner Information Length: 0x14
  Partner System Priority: 32768
  Partner System: Procurve_8f:3a:30 (00:25:61:8f:3a:30)
  Partner Key: 26
  Partner Port Priority: 128
  Partner Port: 3
  Partner State: 0x0d (Activity, Aggregation, Synchronization)
    .... .1 = LACP Activity: Yes
    .... ..0. = LACP Timeout: No
    .... .1.. = Aggregation: Yes
    .... 1... = Synchronization: Yes
    ...0 .... = Collecting: No
    ..0. .... = Distributing: No
    .0.. .... = Defaulted: No
    0... .... = Expired: No
```

Server 2 Switch

```
Frame 9 (124 bytes on wire, 124 bytes captured)
Ethernet II, Src: Procurve_8f:3a:32 (00:25:61:8f:3a:32), Dst: Slow-Protocols (01:80:c2:00:00:02)
Link Aggregation Control Protocol
  Slow Protocols subtype: LACP (0x01)
  LACP Version Number: 0x01
  Actor Information: 0x01
  Actor Information Length: 0x14
  Actor System Priority: 32768
  Actor System: Procurve_8f:3a:30 (00:25:61:8f:3a:30)
  Actor Key: 26
  Actor Port Priority: 128
  Actor Port: 3
  Actor State: 0x3d (Activity, Aggregation, Synchronization, Collecting, Distributing)
    .... ...1 = LACP Activity: Yes
    .... ..0. = LACP Timeout: No
    .... .1.. = Aggregation: Yes
    .... 1... = Synchronization: Yes
    ...1 .... = Collecting: Yes
    ..1. .... = Distributing: Yes
    .0.. .... = Defaulted: No
    0... .... = Expired: No
  Reserved: 000000
  Partner Information: 0x02
  Partner Information Length: 0x14
  Partner System Priority: 4096
  Partner System: IntelCor_3d:91:f7 (00:1b:21:3d:91:f7)
  Partner Key: 1003
  Partner Port Priority: 4096
  Partner Port: 7
  Partner State: 0x3d (Activity, Aggregation, Synchronization, Collecting, Distributing)
    .... ...1 = LACP Activity: Yes
    .... ..0. = LACP Timeout: No
    .... .1.. = Aggregation: Yes
    .... 1... = Synchronization: Yes
    ...1 .... = Collecting: Yes
    ..1. .... = Distributing: Yes
    .0.. .... = Defaulted: No
    0... .... = Expired: No
```

Switch 2 Server

```
jmoekamp@hivemind:~# dladm show-aggr -L
```

LINK	PORT	AGGREGATABLE	SYNC	COLL	DIST	DEFAULTED	EXPIRED
aggregate0	e1000g0	yes	yes	yes	yes	no	no
--	e1000g1	yes	yes	yes	yes	no	no